

This road project paid in part through the
St. Charles County ½ Cent Transportation Sales Tax.

WENTZVILLE PARKWAY SOUTH PHASE 2A

Project Location:

Interstate Drive South to the future connection at Bell Boulevard

Project Description/Scope:

This project will extend the two lane section from Phase 2 south from Interstate Drive to the northern entrance of a proposed future residential subdivision.

Project Funding:

TOTAL \$962,000	County \$420,000	Sponsor \$280,000	Federal	Other \$262,000
--------------------	---------------------	----------------------	---------	--------------------

Anticipated Completion Year: 2024

Sponsor & Contact:

City of Wentzville

Susan Spiegel

636-639-2030

susan.speigel@wentzvillemo.gov

Update: 6/1/2021

CITY OF WENTZVILLE

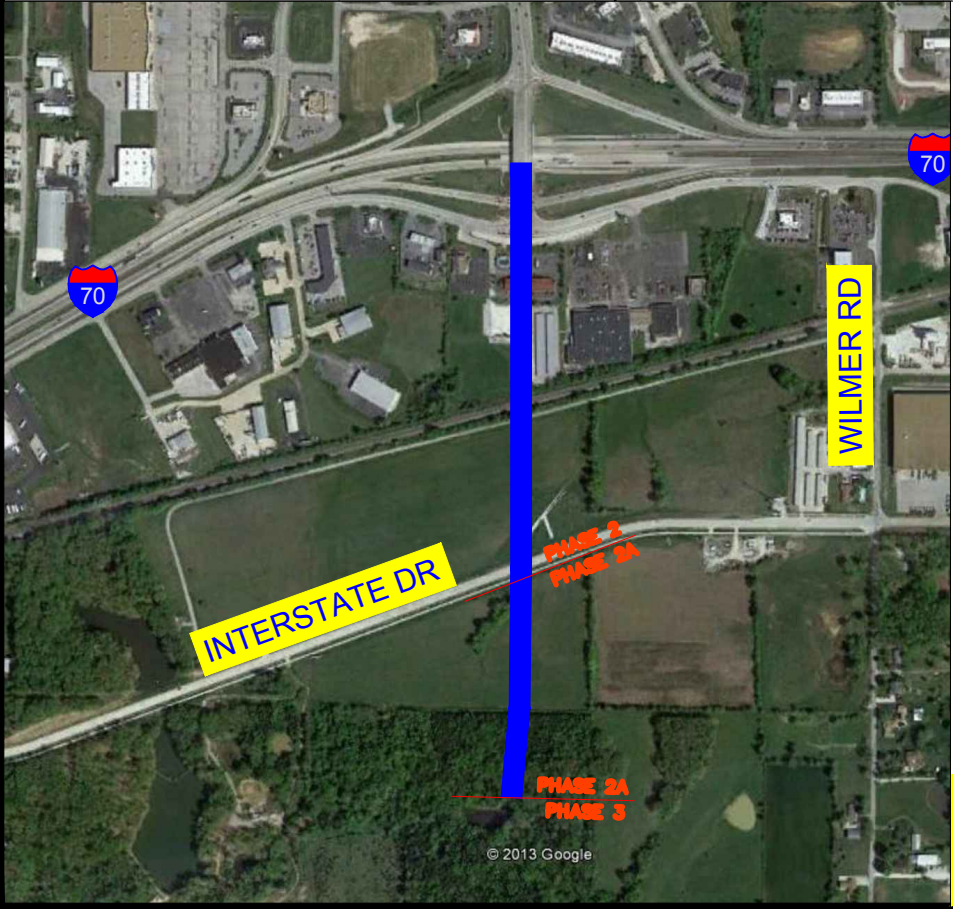
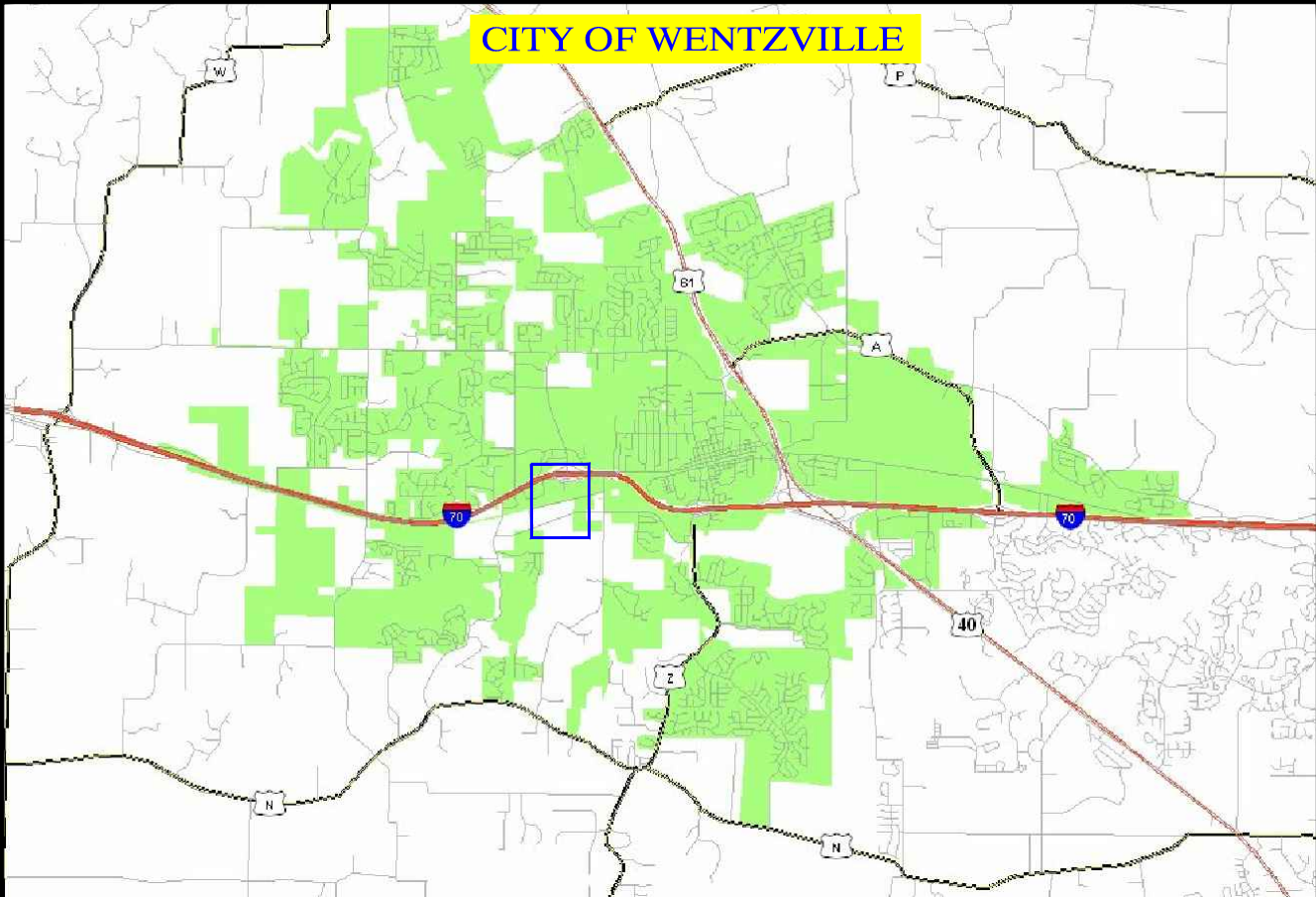

**WENTZVILLE
PARKWAY SOUTH
PHASE 2/2A**

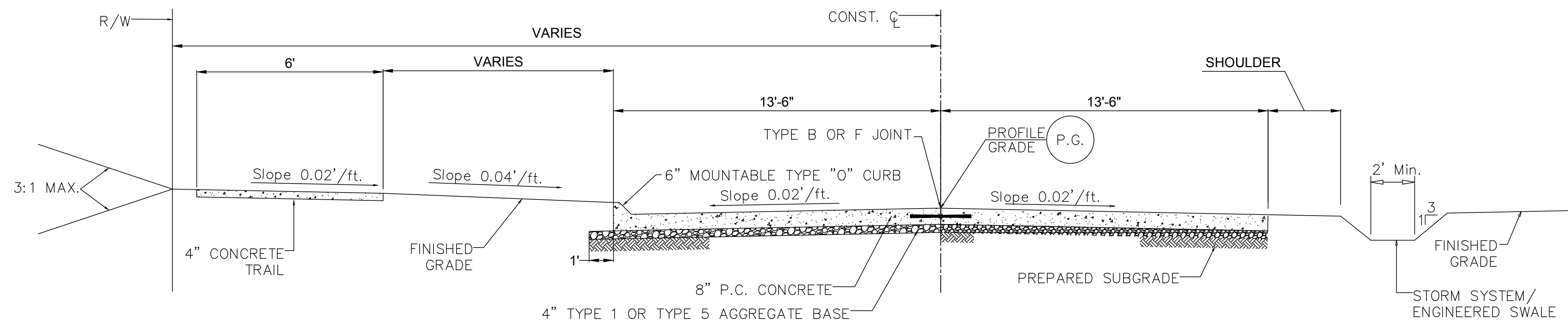

WENTZVILLE PARKWAY
 SOUTH EXTENSION
 TYPICAL
 SECTION

NO.	DATE	BY	REVISION

DATE: 06/12/2018

WNTZ PROJECT NO.:

DESIGNED BY: DRAWN BY:
 CJS
 CHECKED BY: APPROVED BY:

THE RESPONSIBILITY FOR PROFESSIONAL ENGINEERING LIABILITY ON THIS PROJECT IS HEREBY LIMITED TO THE SET OF PLANS AUTHENTICATED UNDER THE SEAL SIGNATURE AND DATE HEREUNDER ATTACHED. RESPONSIBILITY IS DISCLAIMED FOR ALL OTHER ENGINEERING PLANS INVOLVED IN THIS PROJECT AND SPECIFICALLY EXCLUDES REVISIONS AFTER THE DATE UNLESS REAUTHENTICATED.

SEAL

SHEET NUMBER	TOTAL SHEETS
01	01

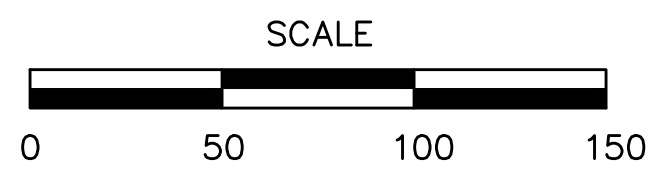

LEGEND

	PROPOSED PROJECT
	FUTURE PROJECT

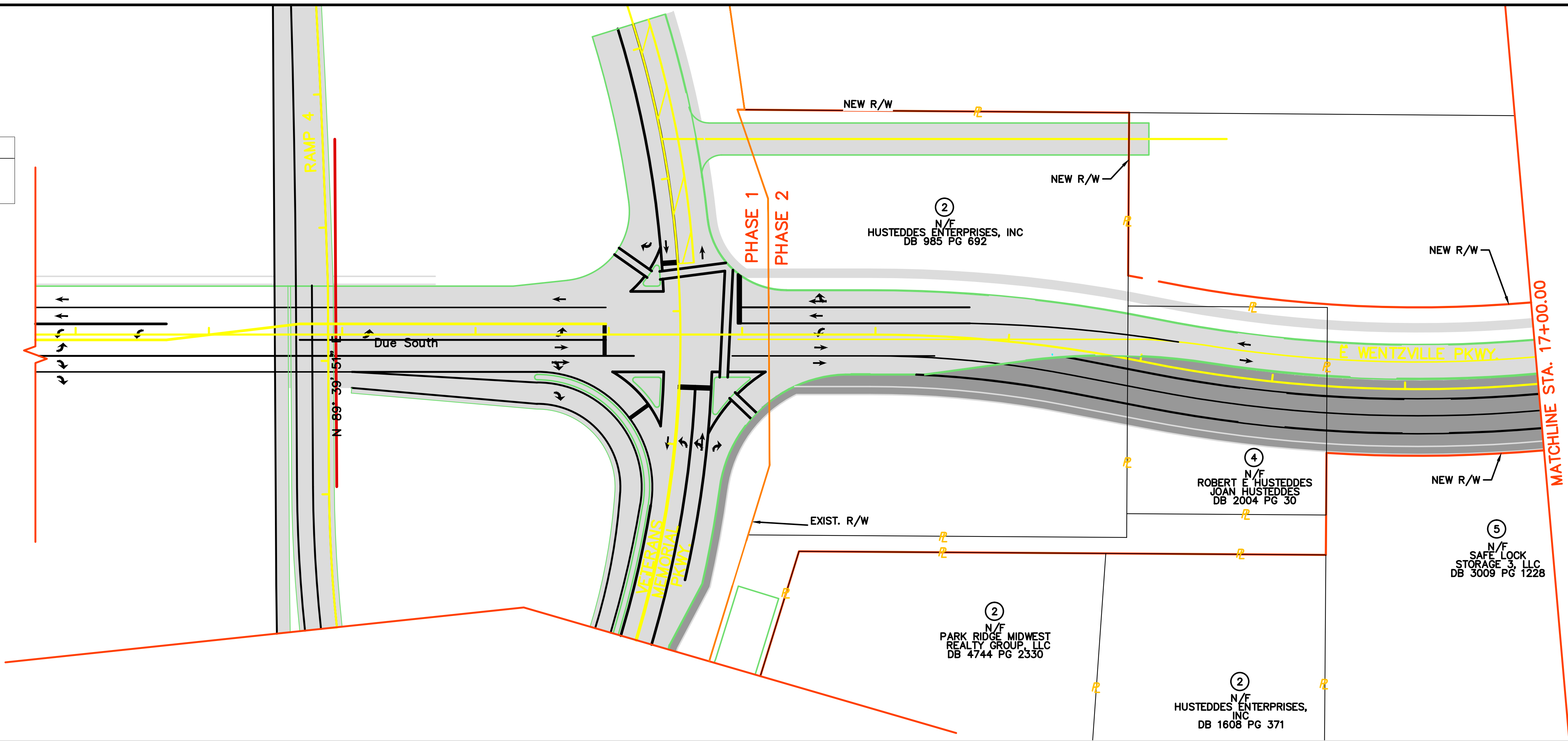

WENTZVILLE PARKWAY
SOUTH EXTENSION
PLAN &
PROFILE

NO.	DATE	BY	REVISION

DATE: 06/12/2018

WNTZ PROJECT NO.:

DESIGNED BY:	DRAWN BY:
CHECKED BY:	APPROVED BY:
	CJS

THE RESPONSIBILITY FOR PROFESSIONAL ENGINEERING LIABILITY ON THIS PROJECT IS HEREBY LIMITED TO THE SET OF PLANS AUTHENTICATED UNDER THE SEAL SIGNATURE AND DATE HEREUNDER ATTACHED. RESPONSIBILITY IS DISCLAIMED FOR ALL OTHER ENGINEERING PLANS INVOLVED IN THIS PROJECT AND SPECIFICALLY EXCLUDES REVISIONS AFTER THE DATE UNLESS REAUTHENTICATED.

SEAL

SHEET NUMBER	TOTAL SHEETS
01	03

12
N/F
COMMERCIAL PROPERTIES
ACQUISITION COMPANY, LLC
DB 5423 PG 2359

N/F
CITY OF WENTZVILLE, MISSOURI
DB 5034 PG 1080

13
N/F
RALPH W. DEMIEN, TRUSTEE
GERTRUDE P. DEMIEN, TRUSTEE
REVOCABLE LIVING TRUST
DB 3899 PG 1144

12
N/F
COMMERCIAL PROPERTIES
ACQUISITION COMPANY, LLC
DB 5423 PG 2359

14
N/F
COMMERCIAL PROPERTIES
ACQUISITION COMPANY, LLC
DB 5423 PG 2359

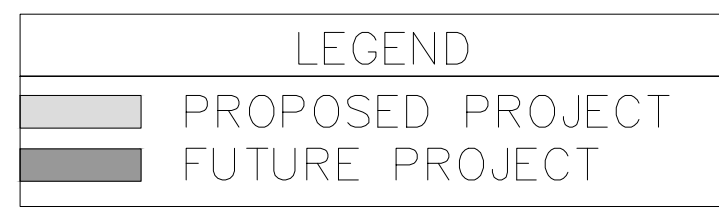
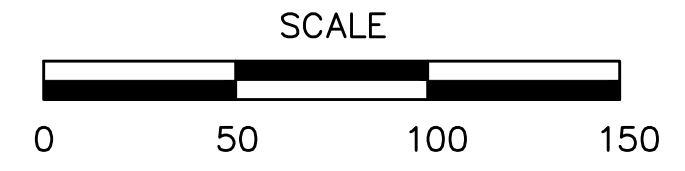

WENTZVILLE PARKWAY
SOUTH EXTENSION
PLAN &
PROFILE

MATCHLINE STA. 17+00.00

MATCHLINE STA. 30+00.00

E WENTZVILLE PKWY.

INTERSTATE DR

PHASE 2
PHASE 2A

N/F
SWANTNER INDUSTRIAL
PARK ASSOCIATION
SWANTNER INDUSTRIAL
PARK PLAT TWO
PB 35 PG 346

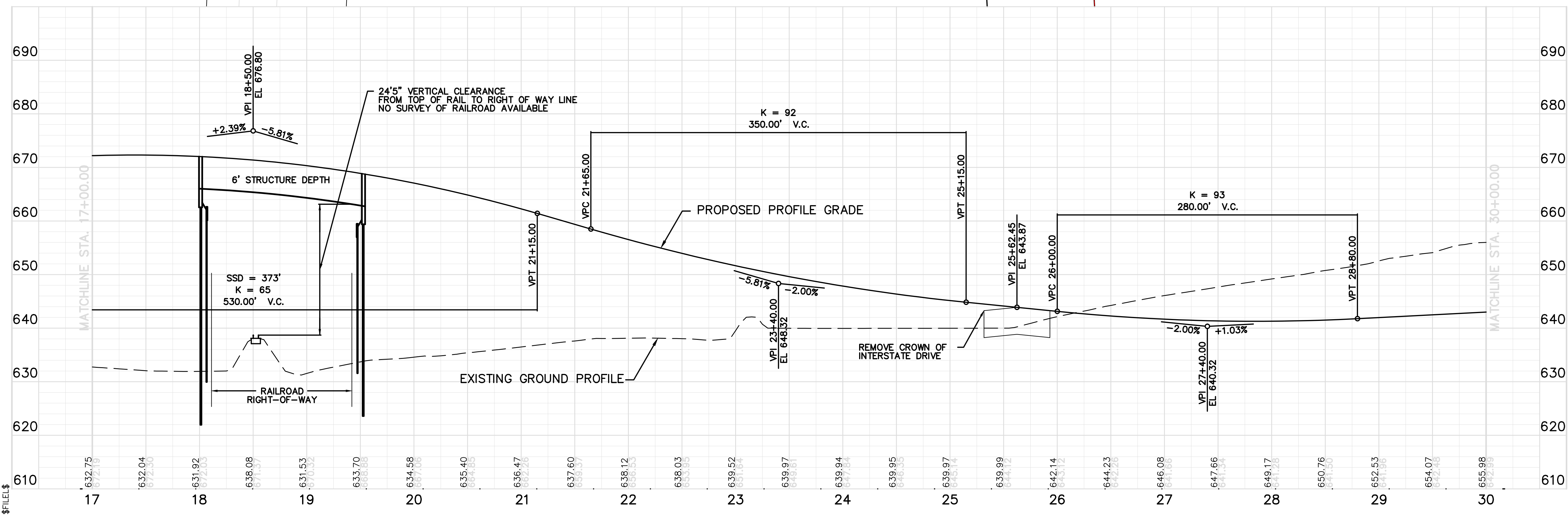

NO.	DATE	BY	REVISION

DATE: 06/12/2018

WNTZ PROJECT NO.:

DESIGNED BY: DRAWN BY:
CJS

CHECKED BY: APPROVED BY:

THE RESPONSIBILITY FOR PROFESSIONAL ENGINEERING LIABILITY ON THIS PROJECT IS HEREBY LIMITED TO THE SET OF PLANS AUTHENTICATED UNDER THE SEAL SIGNATURE AND DATE HEREUNDER ATTACHED. RESPONSIBILITY IS DISCLAIMED FOR ALL OTHER ENGINEERING PLANS INVOLVED IN THIS PROJECT AND SPECIFICALLY EXCLUDES REVISIONS AFTER THE DATE UNLESS REAUTHENTICATED.

SEAL

SHEET NUMBER	TOTAL SHEETS
02	03

15
N/F
THE YOUNG MEN'S CHRISTIAN
ASSOCIATION OF GREATER ST. LOUIS
DB 4894 PG 696

17
N/F
GERTRUDE R. DEMIEN, TRUSTEE
THE DEMIEN FAMILY TRUST
DB 4892 PG 1495

16
N/F
WILMER FARMS
DB 1886 PG 644

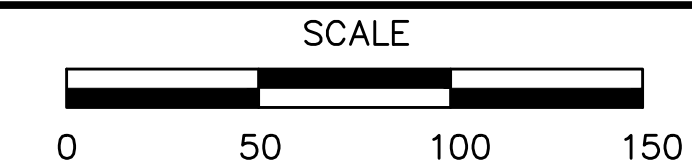

LEGEND

	PROPOSED PROJECT
	FUTURE PROJECT

MATCHLINE STA. 30+00.00

E WENTZVILLE PKWY.

PHASE 2A
PHASE 3

MATCHLINE STA. 43+00.00



Wentzville Missouri
The Crossroads of the Nation
PUBLIC WORKS DEPARTMENT
1001 SCHROEDER CREEK BLVD.
WENTZVILLE, MISSOURI 63385
PHONE (636) 327-5101 FAX (636) 639-2017

WENTZVILLE PARKWAY
SOUTH EXTENSION
PLAN &
PROFILE

NO.	DATE	BY	REVISION

DATE: 06/12/2018

WNTZ PROJECT NO.:

DESIGNED BY:	DRAWN BY:
CHECKED BY:	APPROVED BY:
	CJS

THE RESPONSIBILITY FOR PROFESSIONAL ENGINEERING LIABILITY ON THIS PROJECT IS HEREBY LIMITED TO THE SET OF PLANS AUTHENTICATED UNDER THE SEAL SIGNATURE AND DATE HEREUNDER ATTACHED. RESPONSIBILITY IS DISCLAIMED FOR ALL OTHER ENGINEERING PLANS INVOLVED IN THIS PROJECT AND SPECIFICALLY EXCLUDES REVISIONS AFTER THE DATE UNLESS REAUTHENTICATED.

SEAL

SHEET NUMBER	TOTAL SHEETS
03	03